

# SPIROVENT® SUPERIOR S250



# User Manual

## Copyright ©

All rights reserved. No part of this manual may be duplicated and/or made public through the Internet, by means of printing, photocopying, microfilm or in any other way without prior written permission from Spirotech bv.

# Contents

<b>1</b>	<b>Introduction.....</b>	<b>6</b>
1.1	About the unit in this document.....	6
1.2	Intended use.....	6
1.3	About this document.....	6
1.4	Scope of the delivery.....	6
1.5	Symbols used in this document.....	7
1.6	Related documents.....	7
<b>2</b>	<b>Safety.....</b>	<b>8</b>
2.1	Safety instructions.....	8
<b>3</b>	<b>Technical specifications.....</b>	<b>9</b>
3.1	Operating conditions.....	9
3.2	General specifications.....	9
3.3	Operating characteristics.....	9
3.4	Electrical specifications.....	9
3.5	Performance specifications.....	10
3.6	Dimensions.....	10
3.7	Required free space around the unit.....	11
<b>4</b>	<b>Installation.....</b>	<b>12</b>
4.1	Installation conditions.....	12
4.2	Installation instructions.....	12
4.3	Position the drilling template on the wall.....	13
4.4	Prepare the wall mounting of the unit.....	13
4.5	Mount the unit to the wall.....	14
4.6	Install the branch lines.....	15
4.7	Connect the lines to the unit.....	15
4.8	Connect the BMS to the unit (optional).....	15
	4.8.1 Guide the BMS cable into the unit.....	16
	4.8.2 Connect the BMS cable to the control panel.....	16
<b>5</b>	<b>Commissioning.....</b>	<b>17</b>
5.1	Commissioning instructions.....	17
5.2	Open the inlet line.....	17
5.3	Deaerate the unit.....	17
5.4	Open the outlet line.....	18
5.5	Activate the unit.....	18

<b>6</b>	<b>Operation.....</b>	<b>19</b>
6.1	User interface description.....	19
6.1.1	Overview of the user interface.....	19
6.1.2	Buttons and indicators.....	20
6.1.3	Color codes of the status indicator LEDs.....	20
6.1.4	Operating modes.....	20
6.1.5	Booster function.....	22
6.1.6	Last fill-time (item no. 7).....	22
6.1.7	Pump input signal (item no. 8).....	22
6.1.8	Pump feedback signal (item no. 9).....	22
6.1.9	Total degassing hours.....	22
6.1.10	Weekend break.....	23
6.1.11	Default degassing settings.....	23
6.1.12	User settings / menu items.....	24
6.2	Start up the unit.....	24
6.3	Shut down the unit.....	25
6.4	Navigate the display of the control panel.....	25
6.5	Change a setting.....	25
6.6	Reset a warning or error.....	25
<b>7</b>	<b>Description.....</b>	<b>26</b>
7.1	Overview of the unit.....	26
7.2	Overview of the PCB of the control panel.....	27
7.2.1	BMS connector (NO-C-NC).....	28
7.2.2	Connector of the power cable.....	28
7.3	Wiring diagram.....	29
7.4	Working principle of the degassing process.....	30
7.5	CE and UK CA marking.....	30
7.6	Identification of the unit.....	31
7.6.1	Type plate.....	31
7.6.2	Location of the type plate.....	32
<b>8</b>	<b>Access to parts.....</b>	<b>33</b>
8.1	Get access to the hydraulic parts and the PCB of the control panel.....	33
8.2	Remove or install the cover.....	33
8.3	Get access to the hydraulic parts.....	33
8.4	Get access to the PCB of the control panel.....	34
<b>9</b>	<b>Maintenance.....</b>	<b>35</b>
9.1	Maintenance instructions.....	35
9.2	Maintenance schedule.....	35

---

9.3	Take the unit out of operation.....	35
9.3.1	Close the system valves.....	36
9.3.2	Drain the unit.....	36
9.4	Clean the Y-strainer (filter).....	37
9.5	Replace the automatic air vent.....	37
<b>10</b>	<b>Troubleshooting.....</b>	<b>38</b>
10.1	Troubleshooting instructions.....	38
10.2	Function codes (warnings and errors).....	38
10.3	Troubleshooting table.....	39
10.4	Clean the spray nozzle.....	41
10.5	Unblock the pump.....	42
10.6	Clean the check valve of the outlet.....	42
10.7	Clean the venturi.....	43
10.8	Remove the venturi.....	43
10.8.1	Remove the top T-bend.....	44
10.8.2	Remove the pump.....	44
10.8.3	Remove the bottom T-bend.....	45
<b>11</b>	<b>Guarantee.....</b>	<b>46</b>
11.1	Terms of guarantee.....	46
<b>12</b>	<b>Spare parts.....</b>	<b>47</b>
12.1	Replace a part.....	47
12.2	Spare parts.....	47
<b>13</b>	<b>Maintenance card.....</b>	<b>49</b>
<b>14</b>	<b>EC Declaration of conformity.....</b>	<b>50</b>
<b>15</b>	<b>UK Declaration of conformity.....</b>	<b>51</b>

# 1 Introduction

## 1.1 About the unit in this document

The SpiroVent Superior S250 is an automatic vacuum degasser.

- For an overview of the unit, refer to section [7.1](#).

This document applies to the product type with the article number shown below.

Type	Article number	Description
S250	MV02A50	Automatic vacuum degasser

## 1.2 Intended use

The unit removes dissolved and free gases from the water in heating and non-condensing cooling installations. This way the unit prevents problems in the installations that are caused by such gases.

Do not use the unit for any other purpose.

## 1.3 About this document





- Read the instructions before installation, commissioning and operation. Keep the instructions for future reference.
- The original language of the document is English. All other available language versions are translations of the original instructions.
- The illustrations in this document show a typical setup with relevant details for instructional use only. Differences between the illustrations and the unit are possible but do not have an effect on the comprehensibility of this document.
- This manual has been composed with the utmost care. Should, however, this manual contain any inaccuracies, Spirotech bv cannot be held responsible for this.

## 1.4 Scope of the delivery

- 1x SpiroVent Superior S250
- 1x Quick installation guide (the guide includes a drilling template)
- 1x Quick reference guide
- 1x Safety instructions
- 1x Mounting set

## 1.5 Symbols used in this document

Throughout the instructions the following symbols can be used:

	"Warning" means that personal injury or death is possible and "caution" means that serious damage to the product or environment is possible if you do not follow the instructions
	"Hot parts" is used to give warning about the risk of burns.
	"Electric hazard" is used to give warning about the risk of electric shock.
	"Note" is used to give additional information.

## 1.6 Related documents

Related document	Document number
Pre-mounting instructions	74.437
Safety instructions	61.600
Quick installation guide (including drilling template)	74.383
User manual	74.358
Product Reference Card	74.178

## 2 Safety

### 2.1 Safety instructions

Refer to the safety instructions document for the safety instructions and other safety information.

Read these safety instructions prior to installation. This document is included in the packaging and available on the website. The installation and operation of the unit must be in compliance with the local safety and health regulations and accepted codes of good practice.





## 3 Technical specifications

### 3.1 Operating conditions

The unit is suitable for use in systems filled with clean water that may be partly demineralized or contain additives. Use in combination with other fluids (e.g. glycol or foaming fluids) is not allowed and may result in irreparable damage. The unit should be used within the limits of the technical specifications. Refer to section 3.3. In case of doubt, always contact the supplier.

### 3.2 General specifications

Item	S250
Empty weight [kg]	11
Weight with water [kg]	12
Noise level [dB(A)]	41
Fluid connections	Swivel G1/2"

### 3.3 Operating characteristics

Item	S250
System pressure [bar g]	0.5 - 2.5
Working temperature [°C] (non-condensing)	15 - 70
Ambient temperature [°C]	0 - 40
Maximum system volume [m <sup>3</sup> ]	5
Minimum conductivity [µS/cm]	50

### 3.4 Electrical specifications

Item	S250
Supply voltage [V]	230 +/- 10%
Frequency [Hz]	50
Protection class	IP 44
Maximum load external contact	24V 1A
Fuse	4 A (T)
Supply power connector	Plug F type
Length of supply power cable [mm]	1250
Maximum power consumption [W]	145

### 3.5 Performance specifications

Item	S250
Nominal degassing condition [bar-g]	-0.5
Processing capacity [l/h]	42-74

### 3.6 Dimensions

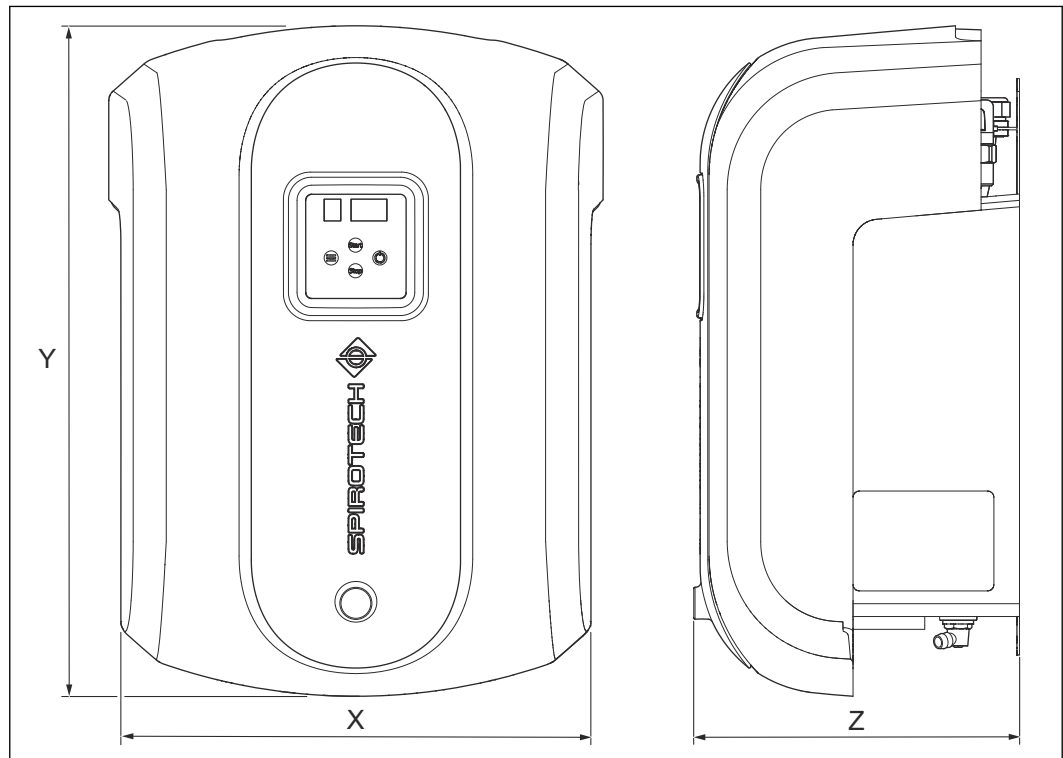

Item	S250
Width [mm] (X)	386
Height [mm] (Y)	524
Depth [mm] (Z)	252

**3.7 Required free space around the unit**

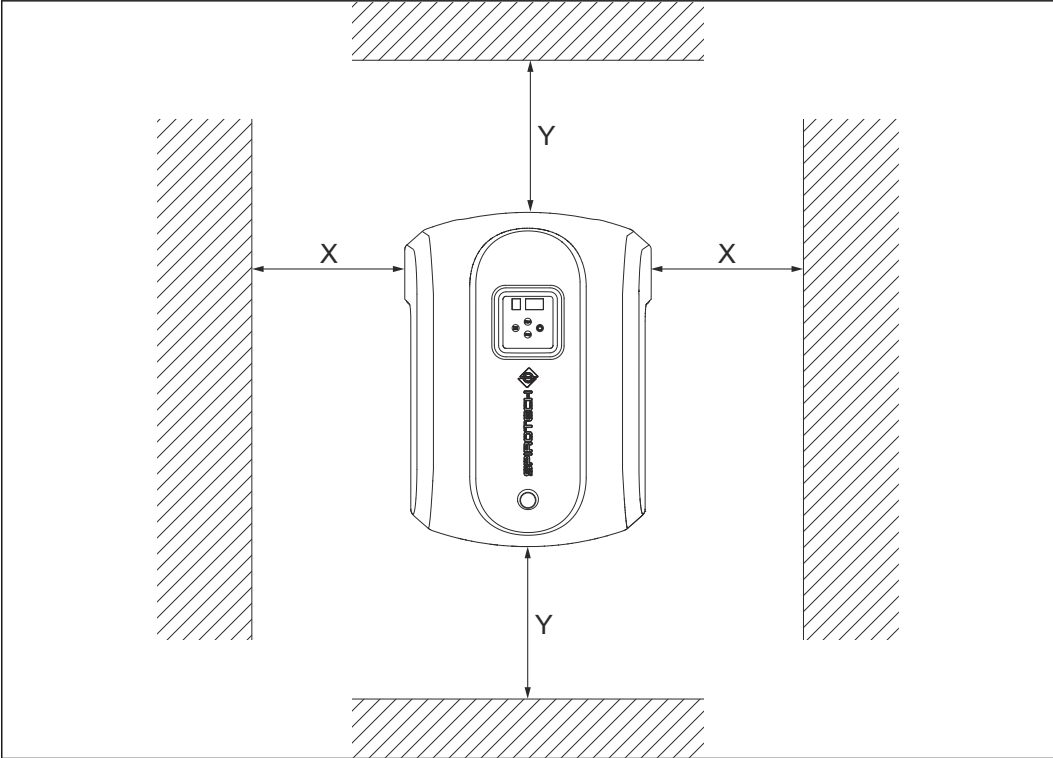

Item	S250
Required free space [mm] (X)	250
Required free space [mm] (Y)	250

## 4 Installation

### 4.1 Installation conditions

- Install the unit in accordance with the local guidelines and rules.
- Install the unit on a frost-free, well-ventilated place inside the building.
- Install the unit to a flat, closed wall that can carry the weight of the unit and the water content. Refer to section [3.2](#).
- Make sure that you maintain a minimum distance around the unit, for service and repair. Refer to section [3.7](#).
- Make sure that the user interface is always easily accessible.
- Install the unit as a bypass on the main line of the installation; preferably in the main return line (15°C – 70°C, non-condensing).
- Make sure there is circulation in the system when the unit is running.
- Make sure that the flexible lines leave the unit at the top.
- In case of a heavily contaminated system fluid, a Spirotech SpiroTrap dirt separator should be installed in the main return line of the installation, in front of the Superior S250. We advise you to follow the VDI2035 guidelines regarding system water quality.
- Make sure that the system is protected by a safety valve and check if the expansion system has the proper dimensions. The water displacement in the unit can cause pressure variations in the installation. Take into account a small extra net expansion volume of 0.5 liters.
- In sound sensitive environments, please provide suitable sound dampers.

### 4.2 Installation instructions

1. Open the box according to the instructions on the box.
2. Position the drilling template on the wall. Refer to section [4.3](#).
3. Prepare the wall mounting of the unit. Refer to section [4.4](#).
4. Take the unit out of the box. Refer to the Quick Installation Guide.



**Caution:**

To prevent damage to the unit, do not put the unit on the ground. Immediately install the unit to the wall.

5. Mount the unit. Refer to section [4.5](#).
6. Install the branch lines. Refer to section [4.6](#).
7. Connect the lines to the unit. Refer to section [4.7](#).
8. Optionally, connect the BMS to the unit. Refer to section [4.8](#).

### 4.3 Position the drilling template on the wall

- Make sure that the conditions of the location meet the requirements. Refer to section [4.1](#).
- The Quick Installation Guide is also a drilling template. Make sure that you read the instructions first. Keep the Quick Installation Guide for future reference.

1. Position the drilling template on the wall. Make sure the display is on eye-height level and keep enough free space around the unit.
2. Put the drilling template against the wall.
  - a. Make sure that there is enough free space around the drilling template.



**Note:**  
For the required free space, refer to section [3.7](#).

- b. Make sure that the template is leveled. Use a spirit level.
3. Attach the drilling template with tape to the wall.
  4. Mark the drilling holes with a pencil.

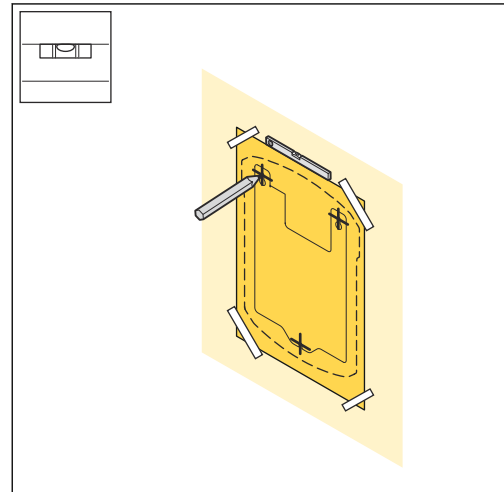

### 4.4 Prepare the wall mounting of the unit



**Note:**  
Make sure that you use the correct mounting materials for the designated wall. Preferably use the mounting materials supplied with the unit.

1. Drill the holes at the marked positions, with a drill size 10 mm.
2. Install the plugs.
3. Install the top screws and washers.



**Note:**  
The screws must protrude 8 mm from the wall. This space is necessary for the mounting of the unit.

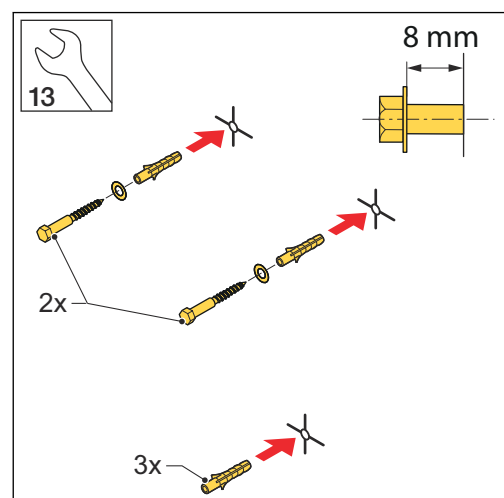

## 4.5 Mount the unit to the wall

**Note:**

To prevent damage to the unit, do not put the unit on the ground. Immediately install the unit to the wall.

1. Mount the unit to the wall.
2. Make sure that the unit hangs correctly on the fasteners.
3. Remove the cardboard spacers which are placed between the components.
4. Install the bottom screw and washer.
5. Tighten the screws.

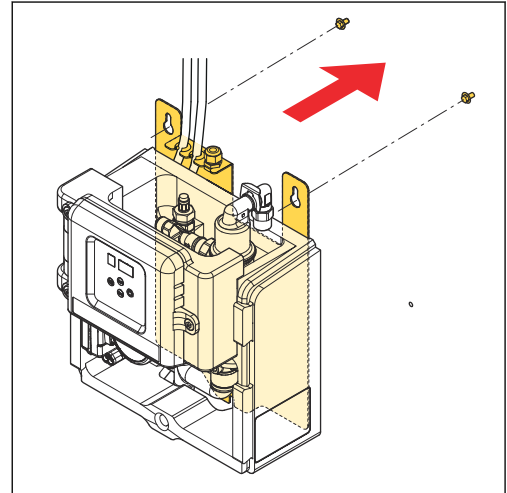

6. Check the angle of the air vent outlet.

**Caution:**

Make sure that the air vent outlet is positioned vertically.

**Note:**

Read the safety instructions before continuing the installation steps.

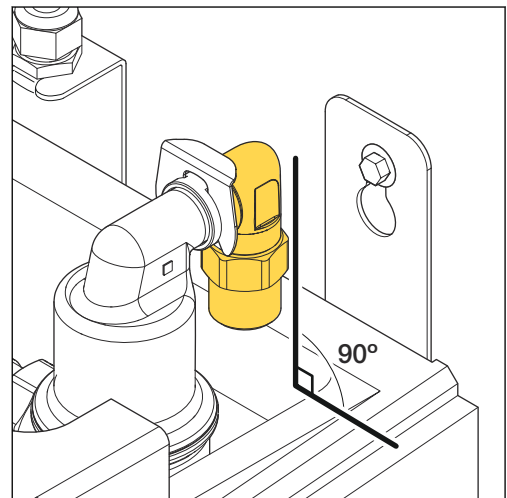

## 4.6 Install the branch lines

1. Make two branch lines 1/2" (A) on the side of the main line, preferably the main return line.
2. Make sure that you connect the hoses to the correct lines. Refer to the labels on the line.
3. Install a full bore service valve (B) to each branch.



**Note:**  
In closed position, the valves isolate the unit from the system. Keep the valves closed until the unit is put into operation.

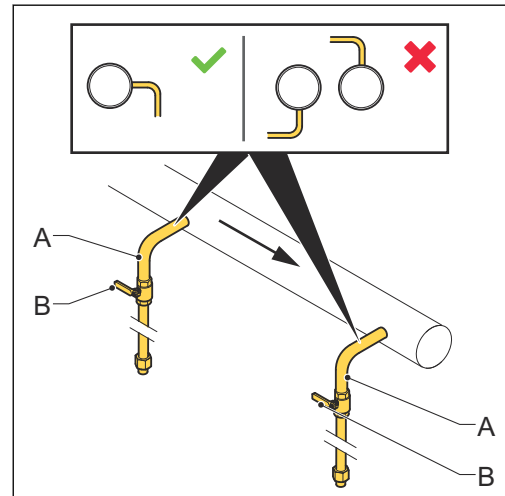

## 4.7 Connect the lines to the unit



**Note:**  
For easy connection, the inlet and outlet lines are labeled. Make sure that you connect the correct lines together.

1. Connect the supply line (A) to the flexible inlet line (B).
2. Connect the return line (C) to the flexible outlet line (D).

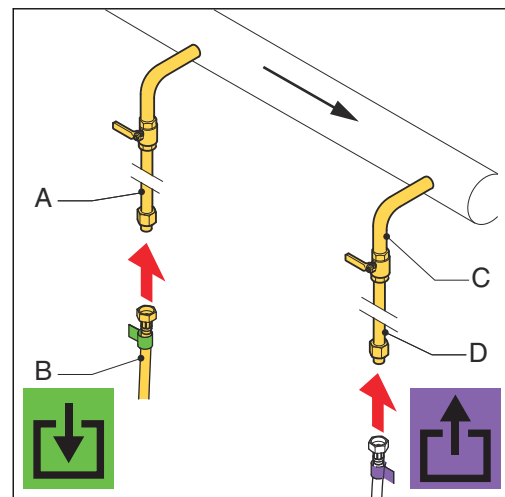

## 4.8 Connect the BMS to the unit (optional)

1. Open the control panel. Refer to section [8.3](#).
2. Remove the backplate of the control panel. Refer to section [8.4](#).
3. Guide the BMS cable into the unit. Refer to section [4.8.1](#).
4. Connect the BMS cable to the control panel. Refer to section [4.8.2](#).
5. Install the backplate of the control panel.
6. Close the control panel.

### 4.8.1 Guide the BMS cable into the unit

1. Guide the BMS cable along the power cable (A).



**Caution:**  
Make sure that the cables do not touch hot parts.

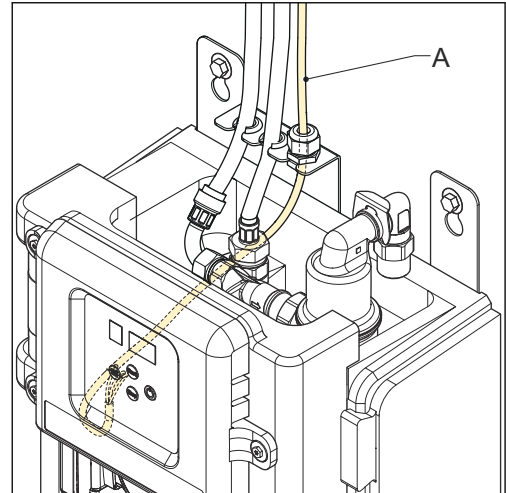

### 4.8.2 Connect the BMS cable to the control panel

For location of the connector, refer to section [7.2](#).

1. Connect the BMS cable to the BMS pins (A) of the connector of the remote monitoring connections.

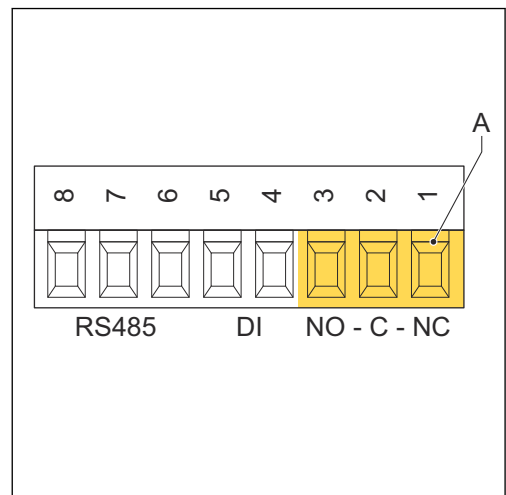



## 5 Commissioning

### 5.1 Commissioning instructions

1. Fill the unit.
  - a. Open the inlet line. Refer to section 5.2.
  - b. Deaerate the unit. Refer to section 5.3.
  - c. Open the outlet line. Refer to section 5.4.
2. Activate the unit. Refer to section 5.5.
3. Install the cover. Refer to section 8.2.
4. If it is required, change a setting. Refer to section 6.5.

### 5.2 Open the inlet line

1. Open the inlet valve (A).
2. Do a check for leakages in the connections.



**Note:**  
If there is a leakage, solve the problem.

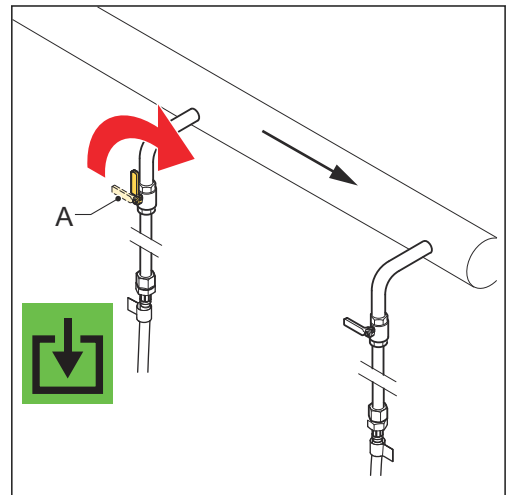

### 5.3 Deaerate the unit

1. Open the control panel.
2. Open the deaeration valve.



**Warning:**

- Hot parts
- Be careful, the liquid medium can be hot.

3. Close the deaeration valve as soon as water comes out of the valve.
4. Close the control panel.

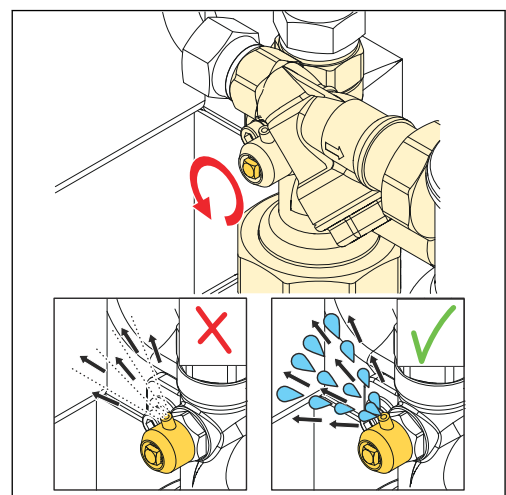

## 5.4 Open the outlet line

1. Open the outlet valve (A).

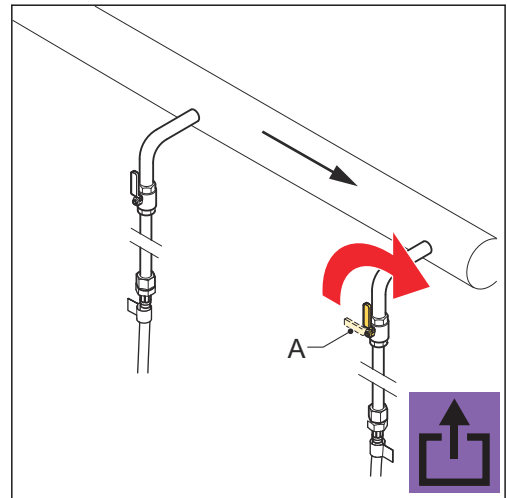

## 5.5 Activate the unit



**Caution:**  
Make sure that the wall socket is grounded.



**Note:**  
Please find more details on the user interface in section [6.1](#).

1. Connect the power cable to the power supply.



**Warning:**

- Risk of electric shock
- Do this step carefully.

The display shows a green status indicator LED and the current system pressure.

2. Push the start button.  
The unit is correctly activated when the display shows these indicators:

- Green status indicator LED
- Status digit: A
- Pressure digits: -.5



**Note:**  
If the display shows an error indication, solve the problem. Refer to section [10.3](#).

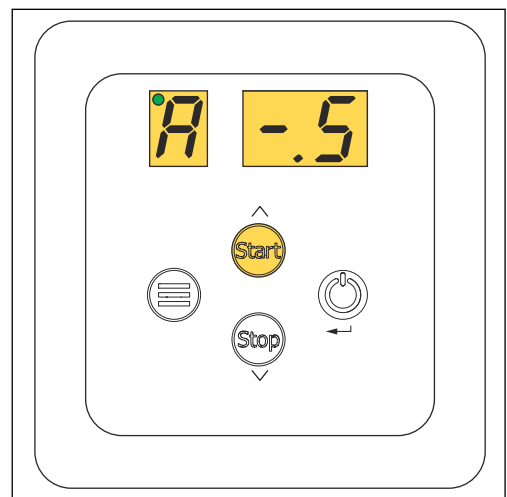

## 6 Operation

### 6.1 User interface description



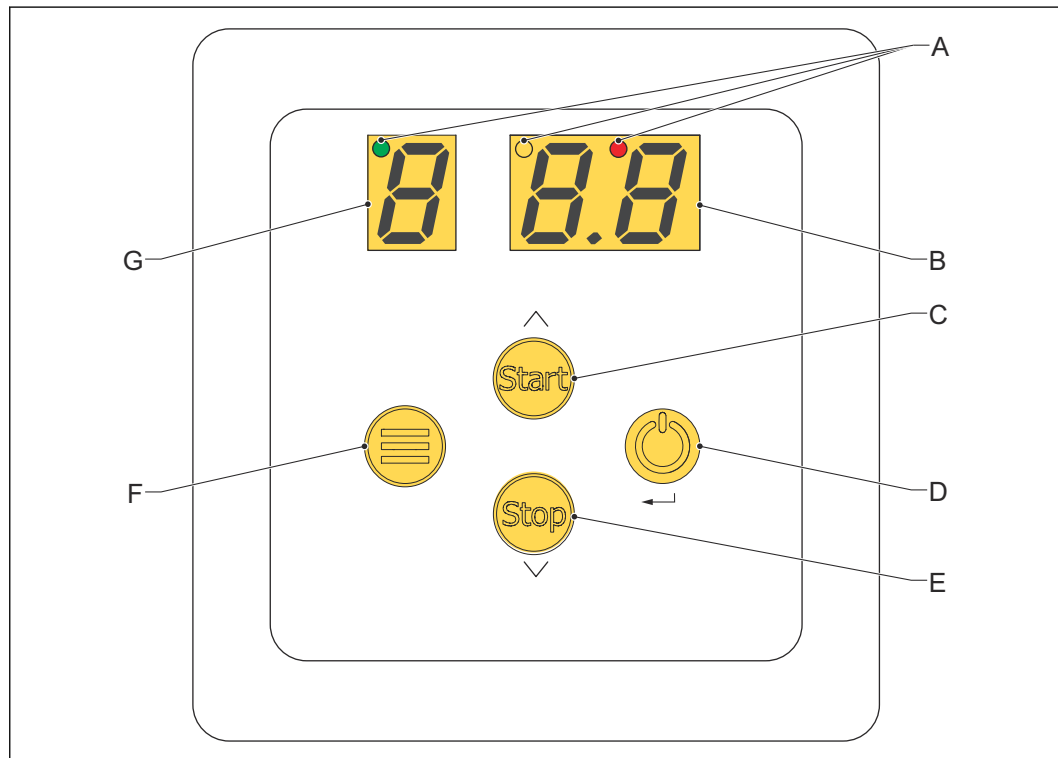

#### 6.1.1 Overview of the user interface



- |   |                              |   |                            |
|---|------------------------------|---|----------------------------|
| A | Status indicator LEDs        | E | Stop / scroll-down button  |
| B | Pressure / item value digits | F | Menu button                |
| C | Start / scroll-up button     | G | Status / item number digit |
| D | Power / enter button         |   |                            |

Item	Situation	Function	Reference
Status indicator LEDs	Process and menu	Show the status of the unit	<a href="#">6.1.3</a>
Buttons	Process and menu	To control the unit	<a href="#">6.1.2</a>
Status / item number digit	Process	Shows actual operating mode	<a href="#">6.1.4</a>
	Menu	Show item number in the menu	<a href="#">6.1.12</a>
Pressure / item value digits	Process	Show the actual system pressure [bar]	-
	Menu	Show the item value of the user setting / menu item	<a href="#">6.1.12</a>

## 6.1.2 Buttons and indicators

Item	Button / indicator	Function
Start / scroll-up button		<ul style="list-style-type: none"> <li>To start the process</li> <li>To go up during navigation</li> <li>To increase a value</li> </ul>
Stop / scroll-down button		<ul style="list-style-type: none"> <li>To stop the process</li> <li>To reset the function code (hold for 3 seconds)</li> <li>To go down during navigation</li> <li>To decrease a value</li> </ul>
Power / enter button		<ul style="list-style-type: none"> <li>To start up the unit</li> <li>To shut down the unit (hold for 3 seconds)</li> <li>To select a menu item</li> <li>To save a setting</li> </ul>
Menu button		<ul style="list-style-type: none"> <li>To go into in the menu</li> <li>To go out of the menu</li> </ul>

## 6.1.3 Color codes of the status indicator LEDs

Color	Position	Status
Green	Left	OK
Orange	Middle	Warning
Red	Right	Error

## 6.1.4 Operating modes

Status / item number digit	Operating mode	Reference
[ ] (blank)	Standby	-
A	Active degassing mode	Section <a href="#">6.1.4.1</a>
P	Pump test mode	Section <a href="#">6.1.4.2</a>
F	Function codes (warning or error)	Section <a href="#">10.2</a>

### Active degassing

The unit will start degassing either manually or automatically:

- Automatically at the daily start time
- Manually press the [start] button

In degassing mode the display will show status letter A and the vessel pressure. After the daily runtime the degassing will stop.

### High Performance Mode

After commissioning the High Performance Mode will automatically be activated. The default daily start time is 8:00 AM and the default degassing run time is 8 hours a day. According to user preference the daily start time (no. 1 in the menu list) and degassing running time (no. 2 in the menu list) is adjustable. The maximum daily degassing run time is 20 hours.

**Automatic Eco Mode**

Four weeks after commissioning the Automatic Eco-mode will be activated to reduce the daily run time automatically. At this point, it can be expected that most dissolved gasses are removed (in the stated operating window). The Automatic Eco mode makes the unit run for 25% of the default daily runtime (2 hours a day) and will continue until another setting is selected.

In case there is a requirement for an extended run time of the unit, for instance after maintenance, water replenishment or a leakage in the system, it is always possible to go back to the High Performance Mode. This is done by activating the booster function. Refer to section 6.1.5.

**Pump test**

When the unit is switched off (outside the season) the pump will run for 10 seconds every day (at the daily starting time).

**Function codes**

Function states (warning or error) will be notified with a function code and an orange or red LED. Orange LED for warnings and red LED for errors. Errors will interrupt the degassing process, warnings will not. During warnings the display will alternately show the degassing indication and a warning indication (function code). Menu item no. 5 gives information about the last 10 function codes. By default it shows the last function code, by pressing select/enter (on/off button) it will start flashing and it will show the date and time of occurrence. You can scroll through the list by pressing the up/down buttons.

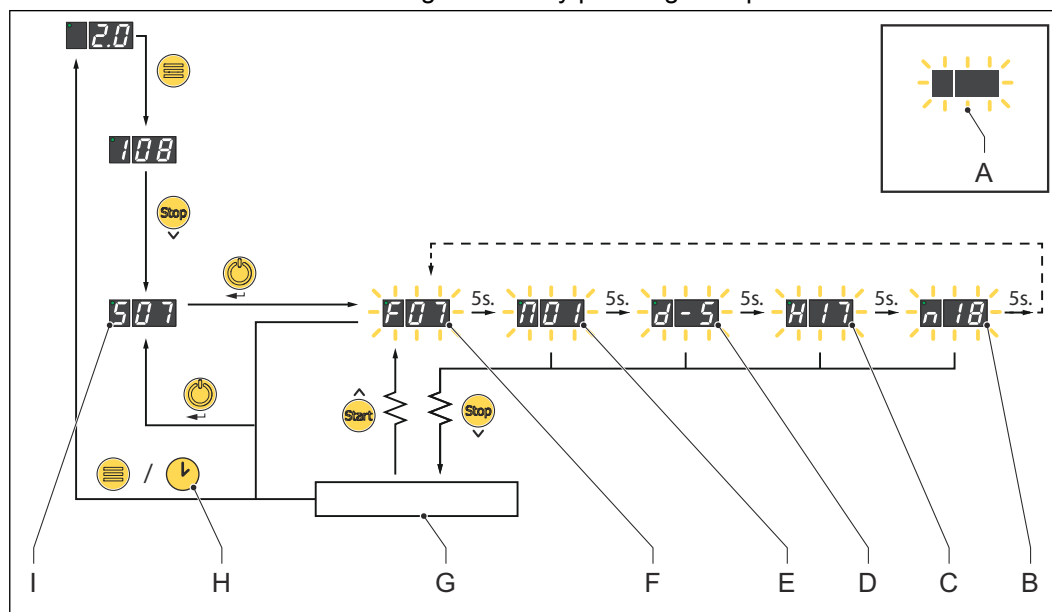

- |   |                          |   |  |
|---|--------------------------|---|--|
| A | Flashing                 | F | Function code 07 (water level is too low) (F 07) |
| B | Minute 18 (n 18)         | G | Last 10 function codes available                 |
| C | Hour 17 (H 17)           | H | Push menu button or wait 5 minutes               |
| D | Day 5 (d -5)             | I | Menu item 5 (5 07)                               |
| E | Month 1 (January) (Π 01) |   |  |



**Note:**

A warning or error can be manually reset by pressing the stop button for 3 seconds. For all function codes, refer to section 10.2.

### 6.1.5 **Booster function**

The booster function is automatically activated each year and/or can be activated manually.

- Automatically at default week number 44
- Manually via set menu item no. 3 to "01"

The booster function re-activates the High Performance Mode at default setting. So daily start time at 8:00 AM and the degassing running time of 8 hours a day. After 4 weeks the system will fall back to the Automatic Eco Mode again.

#### **Automatic yearly booster function**

The yearly activation is aimed to ensure proper system functioning throughout the entire year. As the system could be commissioned or intervened during the warmer period of the year, dissolved gasses may emerge from the system water at the start of the heating season. The automatic yearly booster function is therefore set in week 44.

It is possible to adjust this default week to regional weather conditions by entering menu item nr. 4. Week value 00 however will switch off the automatic yearly booster function.

#### **Manual booster function**

If necessary the period of intensive degassing can be activated manually by setting the booster function; menu item no. 3 to "01". Spirotech advises to do this after any system intervention, like; maintenance, water replenishment or after a leakage in the system.

### 6.1.6 **Last fill-time (item no. 7)**

This value represents the time it took to fill the vessel at the end of the degassing cycle. In case the degassing cycle is interrupted, e.g. after certain function codes (e.g. F07), then the last fill-time is stored as 0.

### 6.1.7 **Pump input signal (item no. 8)**

Pump input signal is an indication of the actual pump set-point.

### 6.1.8 **Pump feedback signal (item no. 9)**

Pump feedback signal is an indication of the actual energy consumption.

### 6.1.9 **Total degassing hours**

Representation is in scientific form and is split into 2 item numbers b.

- The first two digits in menu item b are a number (0.0 - 9.9).
- The second two digits are the exponent that is applicable ( $E^n$ ).

Item no.	Value	Value	Parameters
b	x.	x	0.0 - 9.9
b	E	n	$E^n$ / n = 0-9

**Example**

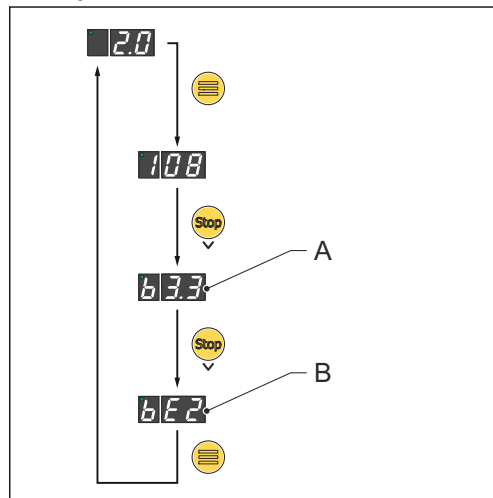

A b 3.3  
 B b E<sup>2</sup>

- The unit has been degassing for  $3.3 \times 10^2$  hours.
- Total degassing time is  $3.3 \times 100 = 330$  hours.

**6.1.10**

**Weekend break**

The weekend break function will prevent the unit from running in the weekend. When menu item no. y is set to "01", the unit is blocked and won't run from Saturday 00:00 until Sunday 23:59.

**6.1.11**

**Default degassing settings**

Item	Parameter
Start time [h]	08:00 AM
Running time, high performance mode [hours]	8
Running time, high performance mode [weeks]	4
Running time, automatic ECO mode [hours]	25% of high performance running time
Running time, pump test mode [seconds]	10
Start time automatic yearly booster function (high performance mode) [week number]	Week 44

## 6.1.12 User settings / menu items

Item no.	Menu item	Default value	Default value	Parameter	Adjustable
1	Daily start [h]	0	8	00 - 23 hours	yes
2	Daily runtime	0	8	01 - 20 hours	yes
3	Manual booster activation [on/off]	0	1	off = 0 / on = 1	yes
4	Programmed booster activation [week number]	4	4	off = 00 / on = 01 - 52	yes
5	Last function code [warning or error]	0	0-9	F01 - F09	
6	Last (re-)start pressure	barg	barg	0.5 - 2.5	
7	Last filling time	sec	sec	00 - 59	
8	Pump input signal [%]	0-9	0-9	00 - 99%	
9	Pump feedback signal [%]	0-9	0-9	00 - 95%	
b	Total degassing hours	x.	x	0.0 - 9.9	
b	Total degassing hours	E	n	E <sup>n</sup> / n = 0 - 9	
c	Installation year	y	y	00 - 99	
c	Installation month	m	m.	01 - 12	
d	Installation day	d	d	01 - 31	
h	Software version	0	1		
n	Actual year	y	y	00 - 99	yes
n	Actual month	m	m.	01 - 12	yes
o	Actual day	d	d	01 - 31	yes
t	Actual hour	h	h	00 - 23	yes
t	Actual minute	m	m.	00 - 59	yes
u	Automatic daylight saving time	0	1	off = 00 / on = 01	yes
y	Weekend break	0	1	off = 00 / on = 01	yes
0	Service menu entrance code	x	x		



### Note:

For an explanation of all the modes and functions, refer to section [6.1.4](#).

## 6.2 Start up the unit

Normally the unit is in stand-by mode. Only in case the unit is switched off, you need to start up the unit.

1. Push the on/off button.  
The unit starts up.
2. Push the start button.  
The unit starts the process.



## 6.3 Shut down the unit

1. Push the stop button.  
The unit finishes the actual process and stops.
2. Push the on/off button for 3 seconds.  
The unit shuts down.



**Note:**

The status LED shows that the unit is still energized.

3. Disconnect the power cable.

## 6.4 Navigate the display of the control panel

For an overview of the menu, refer to section [6.1.12](#).

1. Go into the menu. Push the menu button.
2. Look at the displays to see the current menu item and item value.
3. Scroll through the menu. Use these buttons:
  - a. Push the start button to go up.
  - b. Push the stop button to go down.
4. Push the menu button to go out of the menu.

## 6.5 Change a setting

1. Go to the menu item. Refer to section [6.1.12](#).
2. Push the enter button.  
The value of the setting flashes.
3. Change the value.
  - Push the start button to increase the setting value.
  - Push the stop button to decrease the setting value.
4. Push the enter button to save the setting.

## 6.6 Reset a warning or error



**Note:**

- If it is required, solve the problem. Refer to section [10.1](#).
- For more information on the function codes, refer to section [6.1.4.3](#).

1. Push the stop button for 3 seconds.

## 7 Description

### 7.1 Overview of the unit

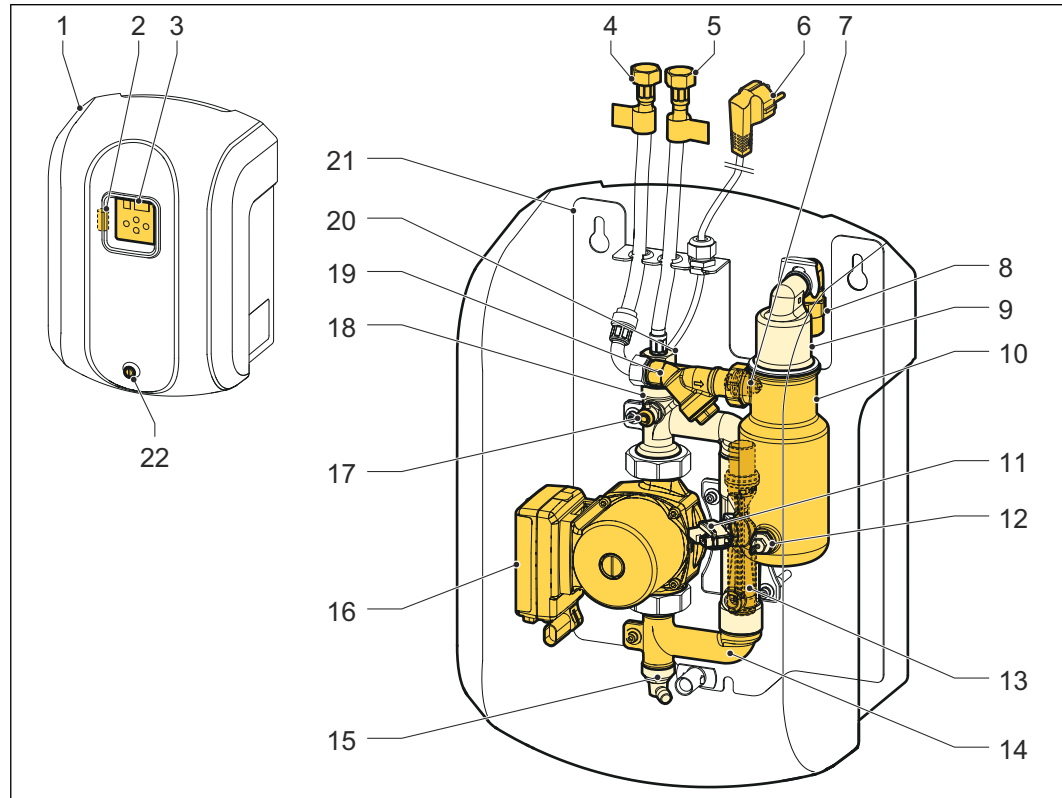

- |    |                             |    |                                  |
|----|-----------------------------|----|----------------------------------|
| 1  | Cover                       | 12 | Level sensor                     |
| 2  | Fuse                        | 13 | Venturi                          |
| 3  | Control panel               | 14 | Bottom T-bend                    |
| 4  | Inlet connection            | 15 | Drain valve                      |
| 5  | Outlet connection           | 16 | Pump                             |
| 6  | Power cable                 | 17 | Manual deaeration valve          |
| 7  | Inlet nozzle                | 18 | Top T-bend                       |
| 8  | Check valve of the air vent | 19 | Y-strainer (including filter)    |
| 9  | Automatic air vent          | 20 | Check valve of the outlet/return |
| 10 | Deaeration vessel           | 21 | Frame and housing                |
| 11 | Pressure sensor             | 22 | Fastening screw                  |

## 7.2 Overview of the PCB of the control panel

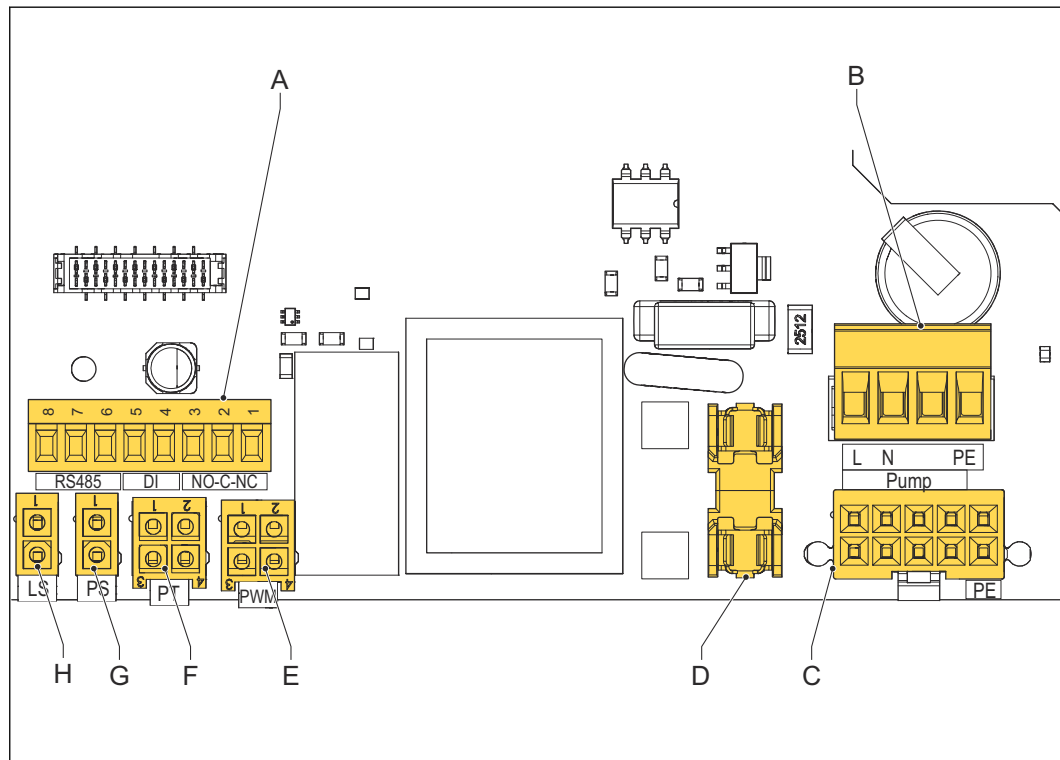

- |   |   |   |                              |
|---|---|---|------------------------------|
| A | BMS connector (NO-C-NC)<br>Refer to section <a href="#">7.2.1</a>       | E | Pump control connector (PWM) |
| B | Connector for the power cable<br>Refer to section <a href="#">7.2.2</a> | F | Pressure sensor (PT)         |
| C | Connector for the pump (power)  | G | Not in use                   |
| D | Fuse  | H | Level sensor (LS)            |

### 7.2.1 BMS connector (NO-C-NC)

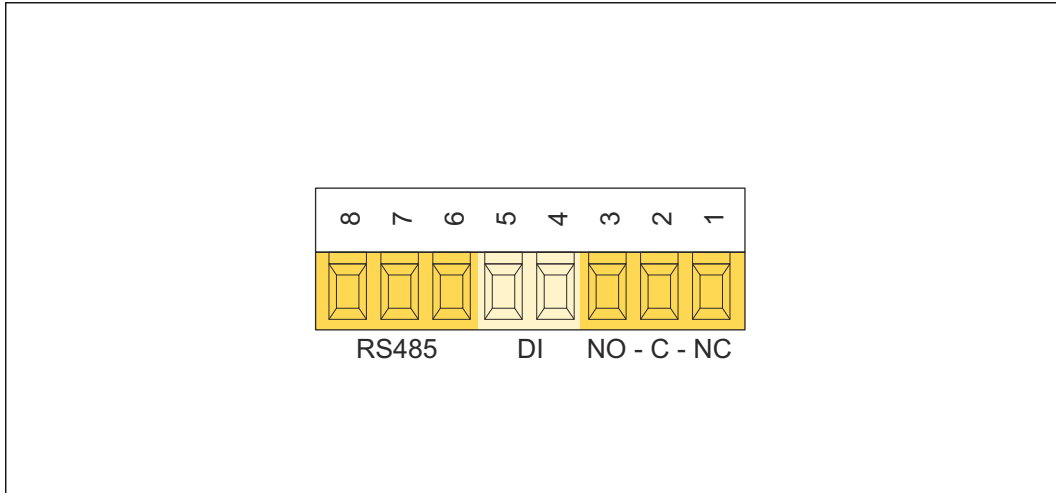

- |   |                       |   |            |
|---|-----------------------|---|------------|
| 1 | Common fault relay NC | 5 | Not in use |
| 2 | Common fault relay C  | 6 | Not in use |
| 3 | Common fault relay NO | 7 | Not in use |
| 4 | Not in use            | 8 | Not in use |

Item	Description	Reference
BMS connector (NO-C-NC)	The unit can be connected to a BMS for remote monitoring.	<a href="#">4.8</a>
DI	Not in use	-
PC connector (RS485)	This connection is for Spirotech quality check only.	-

NC	Normally Closed
C	Common
NO	Normally Open

### 7.2.2 Connector of the power cable

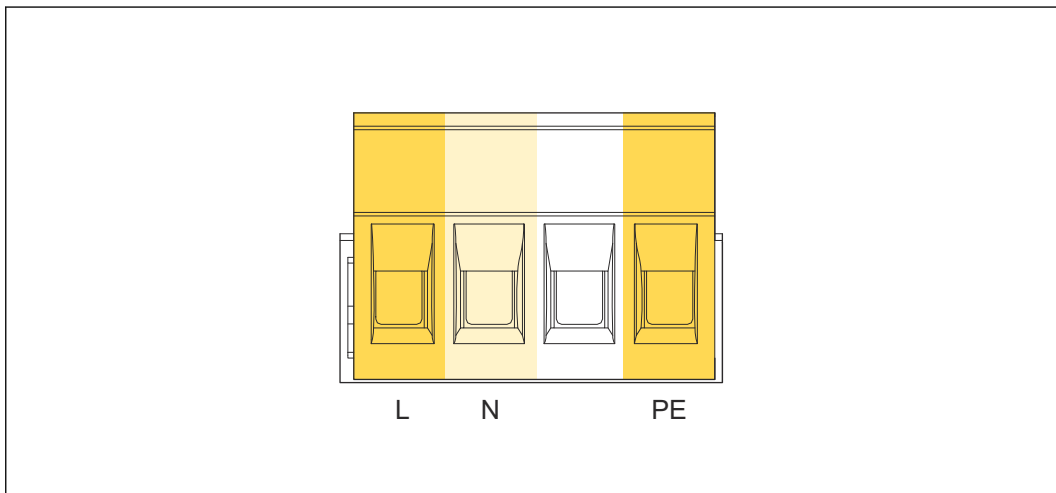

- |   |         |    |                  |
|---|---------|----|------------------|
| L | Live    | PE | Protective earth |
| N | Neutral |    |                  |

7.3 Wiring diagram

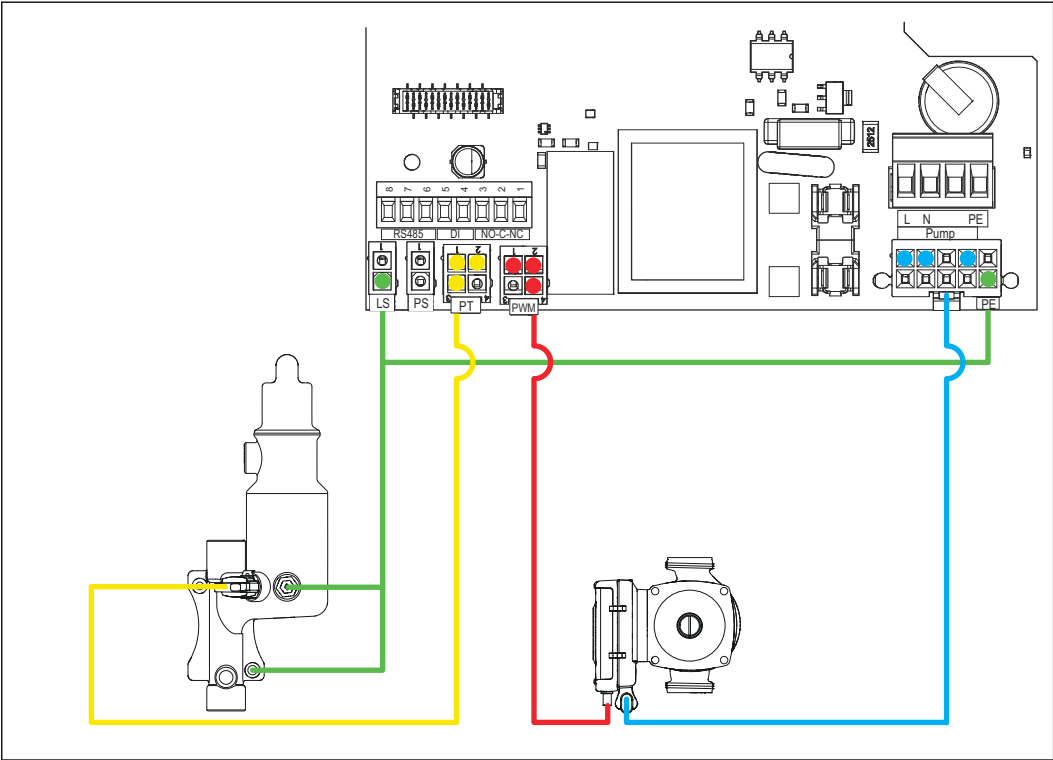

## 7.4 Working principle of the degassing process

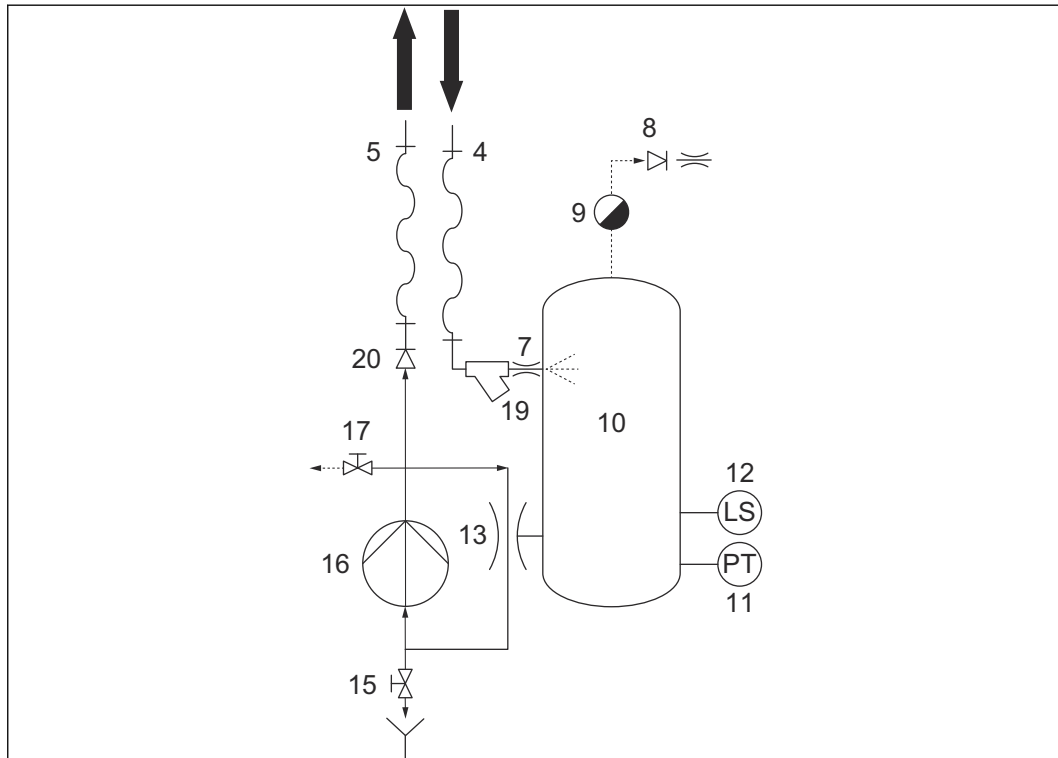

The unit starts the degassing process each day at the daily start time. The degassing process has two phases:

- Vacuum phase
- Air release phase

The pump (16) runs and installation water flows into the vessel (10) through the inlet (4), Y-strainer (19), and nozzle (7). The pump (16) and the venturi (13) create underpressure in the vessel (10) by pumping more water out than gets in. The water level in the vessel (10) will drop and water is sprayed in through the nozzle (7), which causes an effective release of the gasses dissolved in the water. The released gas is collected at the top of the vessel (10). After a few minutes the pump stops.

When the pump (16) stops, the vessel (10) is filled up and the pressure will increase to system pressure causing the released gas to be removed through the automatic air vent (9). After a short period, the pump (16) starts again and a new vacuum phase will start.



**Note:**

The numbers in the scheme refer to the part numbers of the overview of the unit. Refer to section [7.1](#).

## 7.5 CE and UK CA marking

The unit has a CE and UK CA marking. This means that the unit has been designed, constructed, and tested in compliance with the current safety and health regulations, as stated in the declaration of conformity. The unit can be safely used and maintained when you follow the information in this document and its related documents.

## 7.6 Identification of the unit

### 7.6.1 Type plate

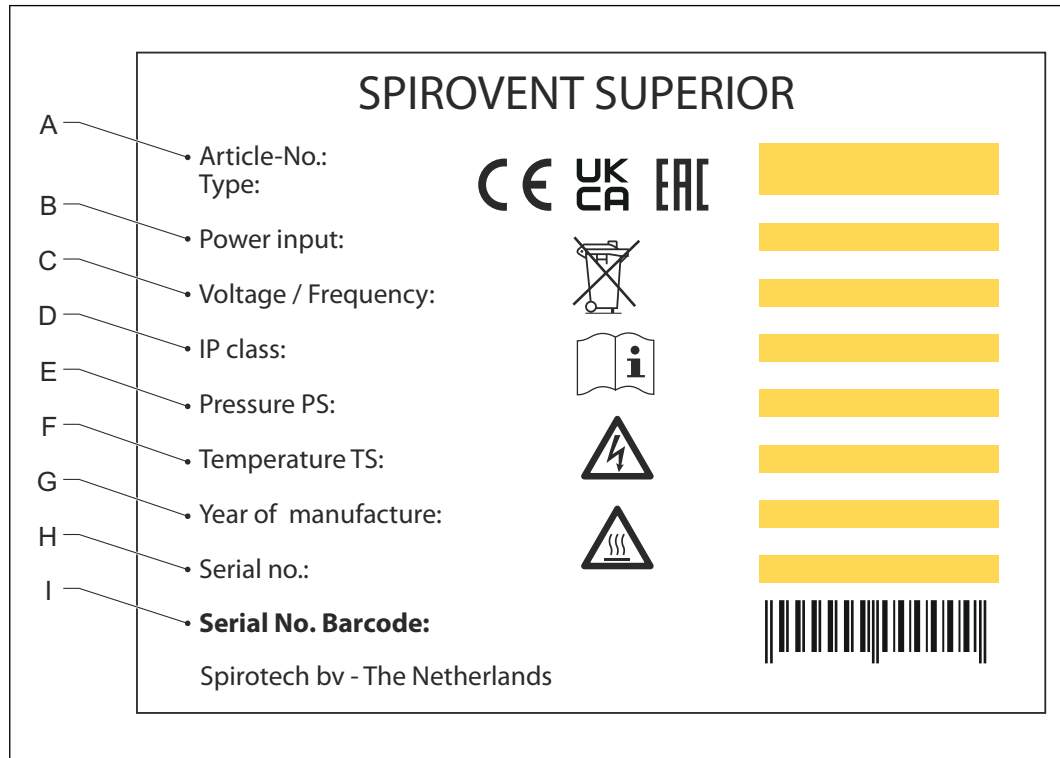

A Article number / unit type  
 B Power input  
 C Voltage / frequency  
 D IP class  
 E System pressure working range

F System temperature  
 G Year of manufacturing  
 H Serial number  
 I Barcode

**7.6.2 Location of the type plate**

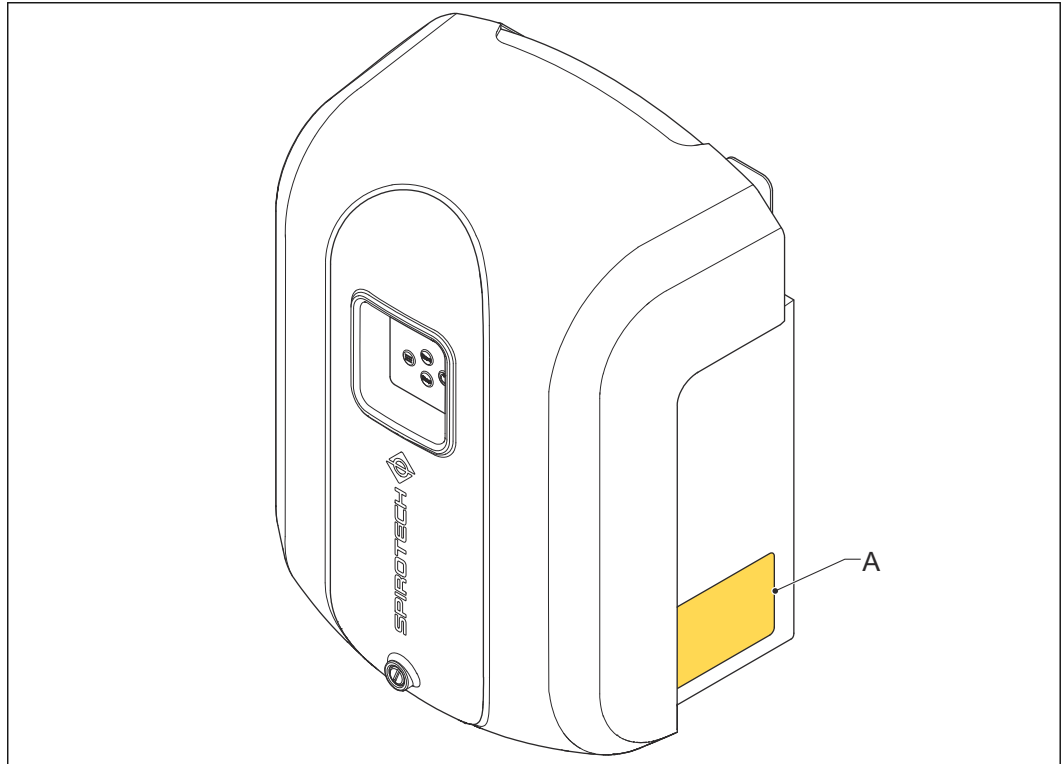

A Type plate



## 8 Access to parts

### 8.1 Get access to the hydraulic parts and the PCB of the control panel

Before you do maintenance, take the unit out of operation. Refer to section 9.3.

1. Remove the cover. Refer to section 8.2.
2. Get access to the hydraulic parts. Refer to section 8.3.
3. Get access to the PCB of the control panel. Refer to section 8.4.

### 8.2 Remove or install the cover

Before you do maintenance, take the unit out of operation. Refer to section 9.3.

1. Remove these items:

- Fastener
- Cover



**Warning:**

- Hot parts
- When removing the cover, parts under the cover may still be hot.

2. Do the steps in reverse to install the cover.

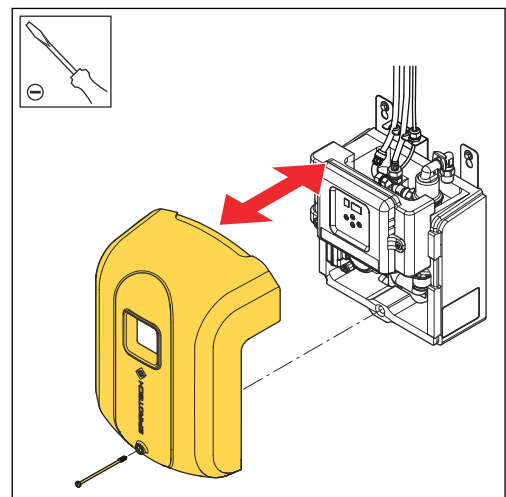

### 8.3 Get access to the hydraulic parts

1. Open the swiveling control panel.



**Warning:**

- Hot parts
- When opening the swiveling control panel, parts under the cover may still be hot.



**Note:**

When you close the swiveling control panel, make sure that the panel is correctly secured in the cams. Do not use force.

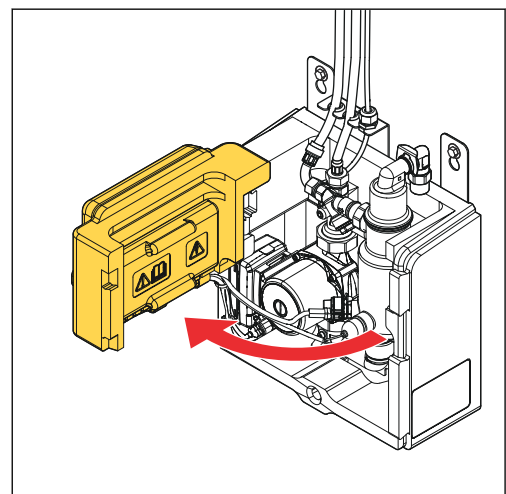

## 8.4 Get access to the PCB of the control panel

1. Pull the backplate out of the control housing to get access to the PCB of the control panel. Use the handles.



**Warning:**

- Risk of electric shock
- Do this step carefully.



**Note:**

When you close the backplate, make sure that the backplate is correctly secured in the cams. Do not use force.

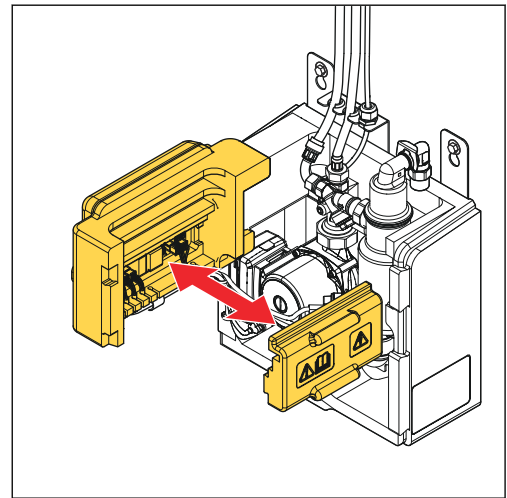

## 9 Maintenance

### 9.1 Maintenance instructions

1. Make sure that you do the preventive maintenance before the limit is exceeded. Use the maintenance schedule. Refer to section [9.2](#).
2. During maintenance, always check the user interface for function codes (warning or error) and visually check for damages and leakages.



**Note:**

If you find a problem, solve the problem. Refer to section [10.1](#).

3. For cleaning or replacement of a part, do the next steps.
  - a. Take the unit out of operation. Refer to section [9.3](#).
  - b. Do the maintenance task.
  - c. When ready, put the unit back in operation. Refer to section [5.1](#).

### 9.2 Maintenance schedule

Item	Task	Limit	Reference
Degassing function	Check	Every year	-
Vacuum pressure	Check	Every year	-
Complete unit	Do a check for damages and leakages.	Every year	-
Y-strainer (filter)	Clean	Every year	Section <a href="#">9.4</a>
Automatic air vent	Replace	Every two years	Section <a href="#">9.5</a>

### 9.3 Take the unit out of operation

1. Shut down the unit. Refer to section [6.3](#).
2. Remove the power plug from the wall socket.



**Warning:**

- Risk of electric shock
- Do this step carefully.

3. Close the system valves. Refer to section [9.3.1](#).
4. If required, let the unit cool down.



**Warning:**

- Risk of burning
- Do this step carefully.

5. Remove the cover. Refer to section [8.2](#).
6. If necessary, drain the unit. Refer to section [9.3.2](#).

### 9.3.1 Close the system valves

1. Close the system valves of these lines:
  - Inlet line (A)
  - Outlet line (B)

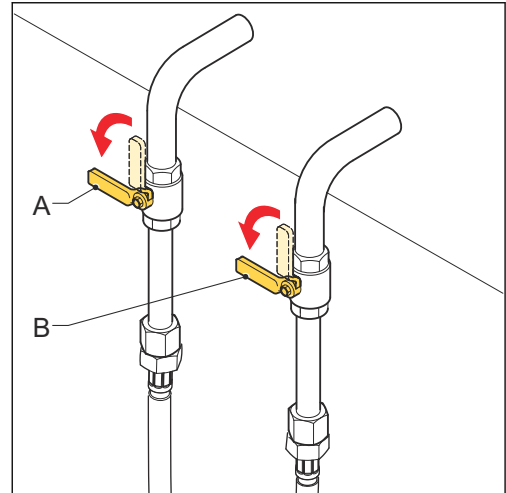

### 9.3.2 Drain the unit

Before you drain the unit, make sure that the system valves are closed. Refer to section [9.3.1](#).

1. Put a container underneath the manual deaeration valve (B).
2. Open the drain valve (A) and then open the manual deaeration valve (B) and drain the unit.



**Warning:**

- Risk of burning
- Do this step carefully.



**Warning:**

- Risk of electric shock
- Do this step carefully.

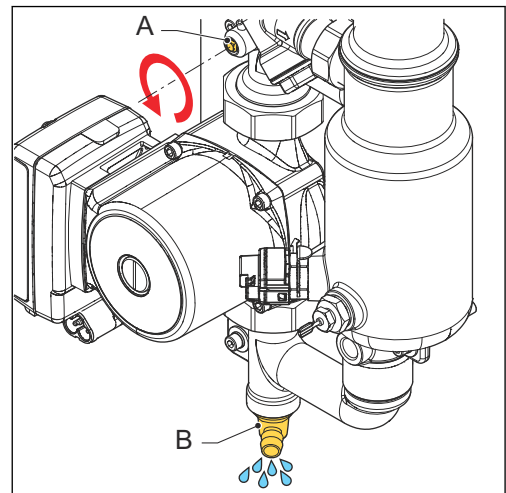

3. To make sure the unit is fully drained, disconnect the inlet hose (C). Collect the fluid that comes out of the inlet hose in a container.
4. When the unit is drained, do these steps:
  - a. Connect the inlet hose.
  - b. Close the drain valve.
  - c. Close the manual deaeration valve.

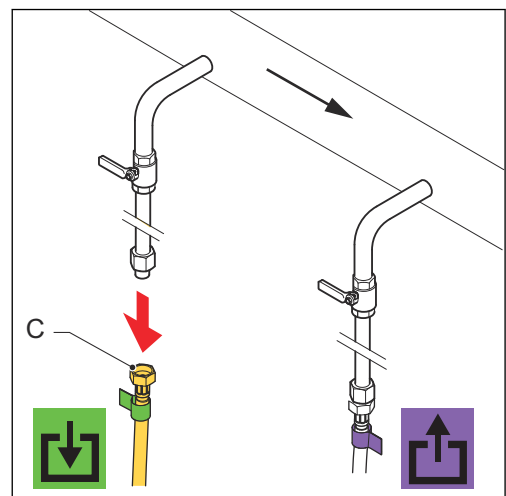

## 9.4 Clean the Y-strainer (filter)

Before you do maintenance, take the unit out of operation. Refer to section [9.3](#).

1. Remove the plug (A). Use a 22 mm spanner.
2. Remove the filter element (B) from the plug.
3. Clean the filter element in water.
4. Put back the filter element in the plug.



**Note:**  
Make sure that the O-ring (C) is correctly positioned on the plug.

5. Make sure that the Y-strainer is positioned pointing downwards.
6. Tighten the plug to the correct torque: 15 Nm.

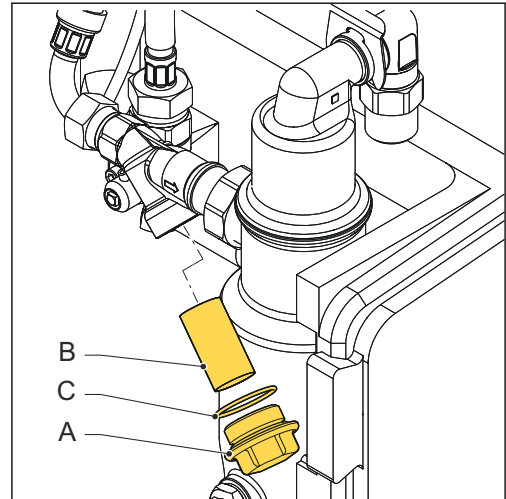

## 9.5 Replace the automatic air vent

Before you do maintenance, take the unit out of operation. Refer to section [9.3](#).

1. Remove the automatic air vent, including the check valve and outlet restriction (A).
2. Install the new parts. For more information see the spare part instructions. Refer to section [12](#).

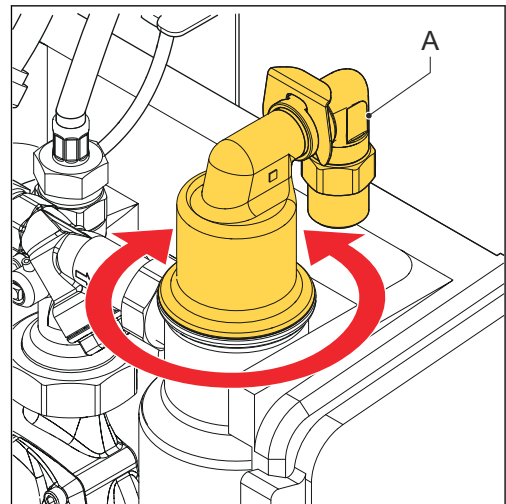

# 10 Troubleshooting

## 10.1 Troubleshooting instructions

1. Find the cause of the problem. Use the troubleshooting table. Refer to section [10.3](#).
2. Before working on the unit, take the unit out of operation. Refer to section [9.3](#).
3. Solve the problem. Use the column "Possible solution" of the troubleshooting table.
4. If the unit is out of operation, do the commissioning instructions. Refer to section [5.1](#).

## 10.2 Function codes (warnings and errors)

Function codes can be either warnings or errors. During warnings degassing will continue. Errors will block the degassing function and always have to be reset. All function codes can be manually reset or they will automatically disappear when the cause of the problem is solved.

- To manually reset the warning, refer to section [6.6](#).
- To solve a problem, refer to section [10.1](#).

Function code	Description	Type	Reset
F01	The system pressure is too low	Error	Automatic / manual
F02	The system pressure is too high	Error	Automatic / manual
F03	Not in use	-	-
F04	There is insufficient vacuum	Warning	Automatic / manual
F05	The filling time is too long	Warning	Automatic / manual
F06	There is no pressure drop after the pump starts	Error	Manual
F07	The water level is too low	Warning <sup>1</sup>	Automatic / manual
F08	Pump failure	Error	Manual
F09	Pressure sensor failure	Error	Manual

<sup>1</sup> F07 is a warning, so the degassing process may continue. However, every time when a low water level is reached, the pump will always stop immediately. When the vessel is full of water, the pump will start automatically again and the process will continue.

### 10.3 Troubleshooting table

Problem	Possible cause	Possible solution
The pressure is too low (F01)	There is a failure or leakage in the system.	Make sure that the system pressure is above 0.5 bar.
	The filter is clogged.	Clean the filter. Refer to section <a href="#">9.4</a> .
	The system valve at the inlet line is closed	Open the inlet line. Refer to section <a href="#">5.2</a> .
	The spray nozzle is clogged.	Clean the spray nozzle. Refer to section <a href="#">10.4</a> .
	The pressure sensor is defective.	Replace the pressure sensor. Refer to section <a href="#">12.2</a> .
The pressure is too high (F02)	There is a failure in the system.	Make sure that the system pressure is below 2.5 bar.
	The pressure sensor is defective.	Replace the pressure sensor. Refer to section <a href="#">12.2</a> .
There is insufficient vacuum (F04)	The system pressure is too high	Make sure that the system pressure is below 2.5 bar.
	The unit is not properly deaerated.	Stop the process and manually deaerate the unit. Refer to section <a href="#">5.3</a> .
	The system valve at the outlet line is closed or partly closed.	Open the outlet line. Refer to section <a href="#">5.4</a> .
	The check valve of the air vent is defective.	Replace the check valve of the air vent. Refer to section <a href="#">12.2</a> .
	The check valve of the outlet is partly clogged.	Clean the check valve of the outlet. Refer to section <a href="#">10.6</a> .
	The venturi is clogged.	Clean the venturi. Refer to section <a href="#">10.7</a> .
	The venturi is defective.	Replace the venturi. Refer to section <a href="#">12.2</a> .
	The pressure sensor is defective.	Replace the pressure sensor. Refer to section <a href="#">12.2</a> .
The filling time is too long (F05)	The system valve at the inlet line is closed	Open the inlet line. Refer to section <a href="#">5.2</a> .
	The spray nozzle is clogged.	Clean the spray nozzle. Refer to section <a href="#">10.4</a> .
	The Y-strainer (filter) is clogged.	Clean the filter element. Refer to section <a href="#">9.4</a> .

Problem	Possible cause	Possible solution
There is no pressure drop after the pump starts (F06)	The system valve at the outlet line is closed or partly closed.	Open the outlet line. Refer to section <a href="#">5.4</a> .
	The unit is not properly deaerated.	Stop the process and manually deaerate the unit. Refer to section <a href="#">5.3</a> .
	The check valve of the outlet is clogged.	Clean the check valve. Refer to section <a href="#">10.6</a> .
	The cable to the pump is not connected.	Connect the cable to the pump. Refer to section <a href="#">10.8.2</a> .
	The cable to the pump is defective.	Replace the cable. Refer to section <a href="#">12.2</a> .
	The pump is defective.	Replace the pump. Refer to section <a href="#">12.2</a> .
The water level is too low (F07)	The water has a very high gas concentration.	This problem is temporarily and will disappear while degassing.
	There are large free air bubbles in the system.	Manually deaerate the unit. Refer to section <a href="#">5.3</a> .
	The automatic air vent is defective.	Replace the automatic air vent. Refer to section <a href="#">12.2</a> .
	There is a problem with the cable of the sensor.	Connect the cable. If the cable is defective, replace the cable. Refer to section <a href="#">12.2</a> .
	The level sensor is defective	Replace the level sensor. Refer to section <a href="#">12.2</a> .
	The inlet hose is warped or buckled.	Straighten the hose.
	The inlet is blocked.	Clean or open the inlet.
	The conductivity of the system water is too low.	Increase the conductivity to >50 $\mu\text{S}/\text{cm}$ . If necessary, contact the supplier of the unit.
Pump failure (F08)	The unit is not properly deaerated.	Stop the process and manually deaerate the unit. Refer to section <a href="#">5.3</a> .
	The pump is blocked.	Unblock the pump. Refer to section <a href="#">10.5</a> .
	The cable to the pump is not connected.	Connect the cable to the pump.
	The cable to the pump is defective.	Replace the cable. Refer to section <a href="#">12.2</a> .
	The pump is defective.	Replace the pump. Refer to section <a href="#">12.2</a> .



Problem	Possible cause	Possible solution
Pressure sensor failure (F09)	Bad connection of the cable of the pressure sensor.	Do a check on the connection between the cable and connector.
	The pressure sensor is defective.	Replace the pressure sensor. Refer to section <a href="#">12.2</a> .
The control panel does not function.	The power is not connected.	Connect the power plug to the wall socket.  In case of an all-pole main switch, set the switch in the on position.
	There is a connection problem with the power cable.	Do a visual check on defects of the power cable and connection. If necessary, replace the power cable.
	The fuse is defective or not correctly connected.	Replace or correctly position the fuse on the PCB. Refer to section <a href="#">12.2</a> .
	The PCB is defective.	Replace the PCB. Refer to section <a href="#">12.2</a> .
	The external power supply does not provide power.	Do a check on the external power supply.

## 10.4 Clean the spray nozzle

Before you do maintenance, take the unit out of operation. Refer to section [9.3](#).

1. Loosen the ring nut (A).
2. Remove the Y-strainer (B).
3. Remove the gasket (C) and the inlet nozzle (D).
4. Clean the inlet nozzle with water. If necessary, use a brush.



**Note:** Before installing the parts, Spirotech advises to replace the gasket. Refer to section [12.2](#).

5. Install the inlet nozzle and the gasket.
6. Install the Y strainer. Make sure that the Y-strainer is positioned pointing downwards.
7. Tighten the ring nut.

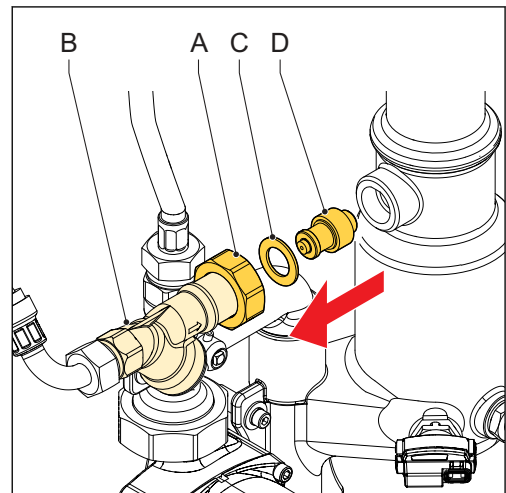

## 10.5 Unblock the pump

Before you do maintenance, take the unit out of operation. Refer to section [9.3](#).

1. Remove the screw (A).

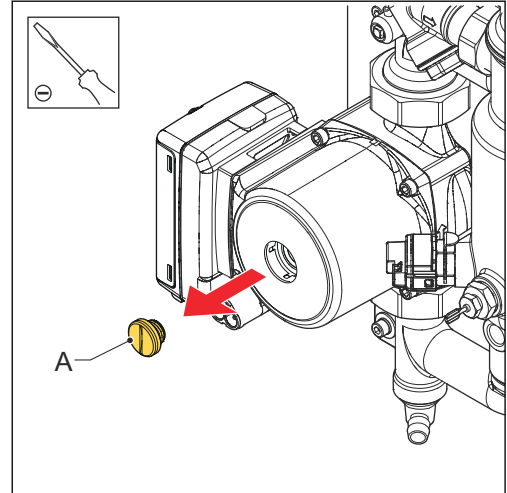

2. Put a screwdriver in the groove of the pump shaft and try to rotate the shaft counterclockwise.



**Note:**  
If unblocking is impossible, replace the pump. Refer to section [12.2](#).

3. Install the screw.

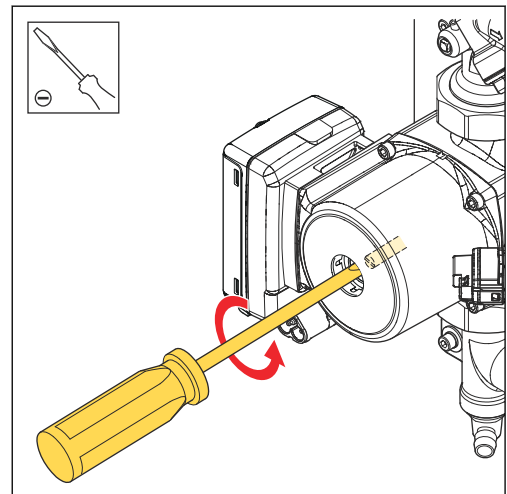

## 10.6 Clean the check valve of the outlet

Before you do maintenance, take the unit out of operation. Refer to section [9.3](#).

1. Loosen the ring nut (A). Disconnect the hose.
2. Remove these parts:
  - Gasket (B)
  - Check valve (C)
  - O-ring (D)

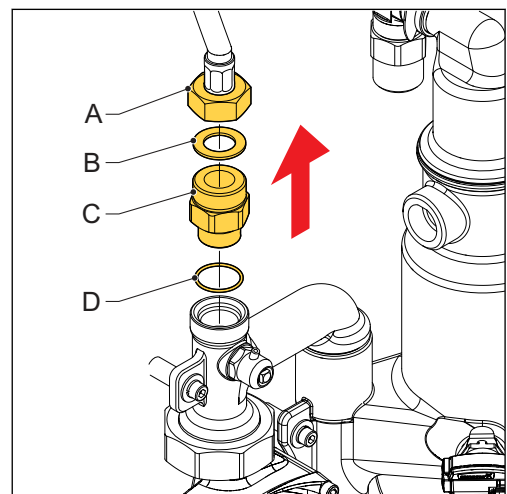

3. Clean the check valve:
  - a. Clean the check valve with water.
  - b. Check for residual debris.
  - c. Gently check if the check valve opens and closes correctly.



**Note:**

Before installing the parts, Spirotech advises to replace the O-ring and gasket. Refer to section [12.2](#).

4. Install the O-ring and check valve. Tighten the check valve.
5. Install the gasket and connect the hose. Tighten the ring nut.
6. Make sure that all parts are watertight.

## 10.7 Clean the venturi

Before you do maintenance, take the unit out of operation. Refer to section [9.3](#).

1. Remove the venturi. Refer to section [10.8](#).
2. Clean the venturi with water. If necessary, use a small soft brush.
3. Check the venturi for damages.



**Note:**

- If the venturi has damages, replace the venturi. Refer to section [12.2](#).
- Before installing the parts, Spirotech advises to replace all O-rings and gaskets on the venturi, T-bends, and pump by new ones (use a little silicone-based lubricant on the O-rings). Refer to section [12.2](#).

4. Install the parts in the reverse order.



**Note:**

Make sure that all parts are tightened watertight.

## 10.8 Remove the venturi

Before you do maintenance, take the unit out of operation. Refer to section [9.3](#).

1. Remove the top T-bend. Refer to section [10.8.1](#).
2. Remove the venturi (A) by pulling it upwards. Use your hands



**Caution:**

To prevent damaging the venturi, do not use tools.

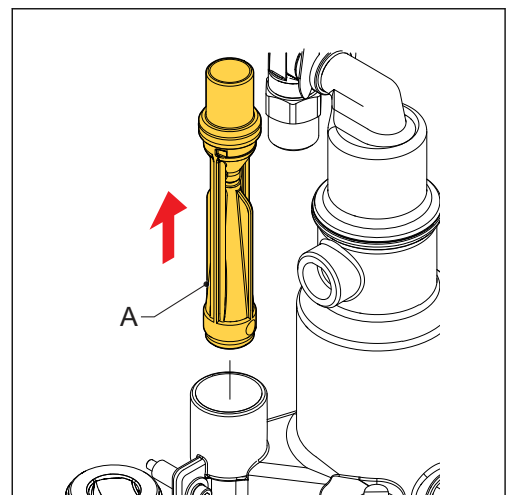

3. If the venturi is stuck, do these steps:
  - a. Remove the pump. Refer to section [10.8.2](#).
  - b. Remove the bottom T-bend. Refer to section [10.8.3](#).
  - c. Remove the venturi by gently pushing the venturi upwards. Use the backside of a screwdriver.

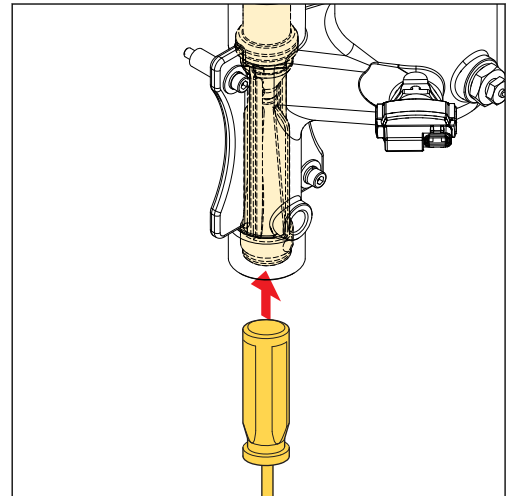

### 10.8.1 Remove the top T-bend

Before you do maintenance, take the unit out of operation. Refer to section [9.3](#).

1. Loosen the ring nut (A).
2. Remove the bolt and washers (B).
3. Remove these parts:
  - Top T-bend (C)
  - Gasket (D)
  - O-rings (E)

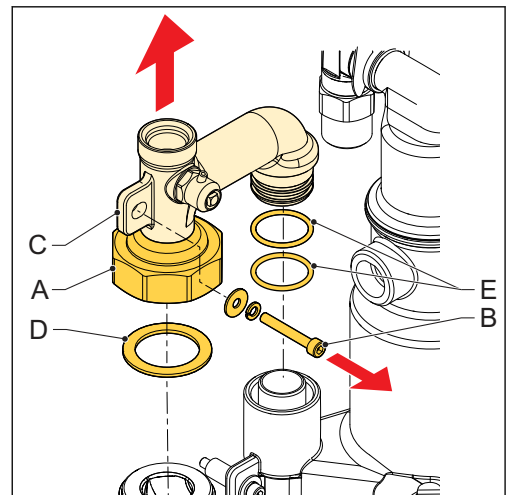

### 10.8.2 Remove the pump

Before you do maintenance, take the unit out of operation. Refer to section [9.3](#).

1. Loosen the ring nut (A).
2. Disconnect the power cable (B).
3. Slide the cable lock (C) to unlock the signal cable (D).
4. Disconnect the signal cable.
5. Remove the pump (E).

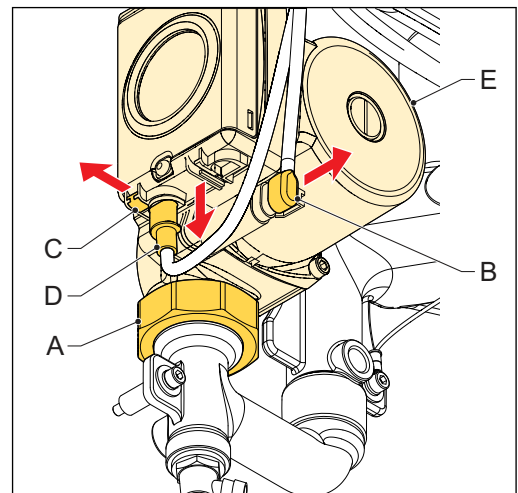

### 10.8.3 Remove the bottom T-bend

Before you do maintenance, take the unit out of operation. Refer to section [9.3](#).

1. Remove the bolt and washers (A).
2. Remove these parts:
  - Bottom T-bend (B)
  - Gasket (C)
  - O-rings (D)

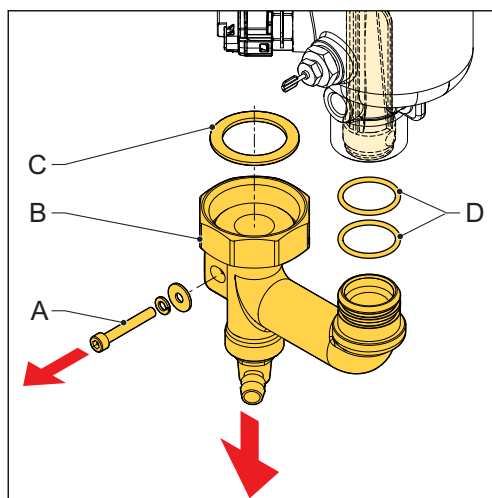

## 11 Guarantee

### 11.1 Terms of guarantee

- The guarantee for this product is valid until 2 years following the purchasing date.
- The guarantee lapses in cases of faulty installation, incompetent use and/or non-authorized personnel trying to make repairs.
- Consequential damage is not covered by the guarantee.

## 12 Spare parts

### 12.1 Replace a part

Before you do maintenance, take the unit out of operation. Refer to section [9.3](#).

1. Order the spare part.

For the spare parts list, refer to section [12.2](#).

2. Upon delivery, unpack the spare part and check for correctness.

3. Replace the part. Follow the spare part instructions, which are included in the delivery of the spare part.

### 12.2 Spare parts

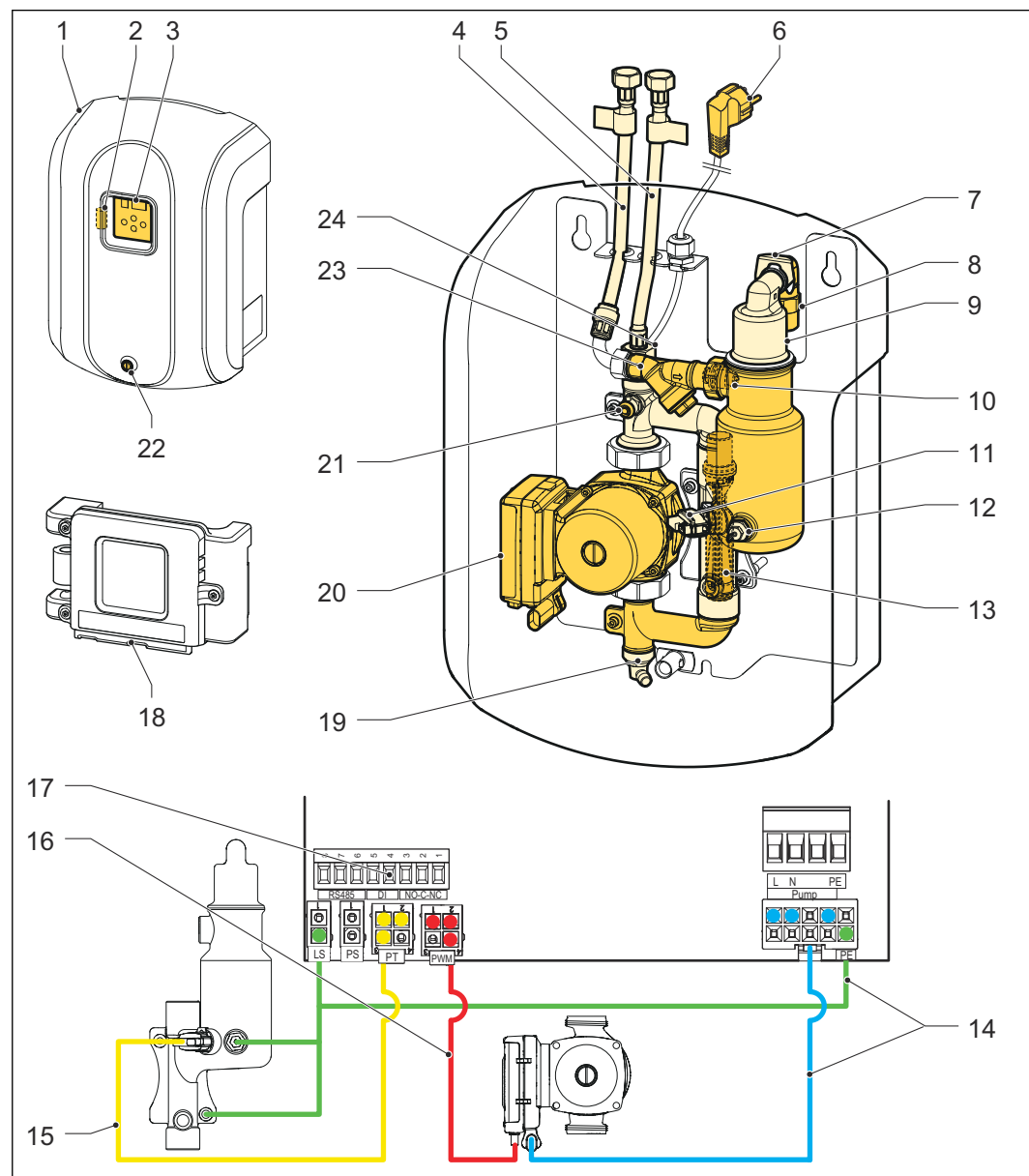

Item	Article	Revision set name
1	R73.977	Cover including Brandplate
2	R74.387	Fuse
3	R73.957	Control - PCB and EPP parts
4	R74.018	Inlet hose
5	R74.015	Outlet hose
6	R74.331	Power cable (F-type plug)
7	R73.222	Clip
8	R73.987	Check valve and Outlet restriction (Air vent)
9	R73.986	Automatic air vent (including Check valve and Outlet restriction)
10	R73.971	Spray nozzle
11	R74.001	Pressure sensor
12	R74.002	Level sensor
13	R73.954	Venturi
14	R74.333	Level sensor cable and Pump power cable
15	R74.332	Pressure sensor cable
16	R74.330	Pump cable - PWM signal
17	R15.395	Connector - External connections
18	R73.974	Control - EPP parts
19	R16.175	Drain valve
20	R73.953	Pump
21	R60.355	Manual deaeration valve
22	R72.953	Fastening screw
23	R73.995	Y-strainer (including filter)
24	R73.988	Check valve outlet/return
-	R73.955	Seal-kit (all replaceable seals)

**Note:**

All spare parts include a document with replacement instructions. Do not remove the defective part until you have these replacement instructions.



# 13 Maintenance card

Type:	_____
Serial number:	_____
Installation date:	_____
Installed by firm:	_____
Installed by technician:	_____

Inspection date:	Technician:	Initials:
Nature of the maintenance:		

Inspection date:	Technician:	Initials:
Nature of the maintenance:		

Inspection date:	Technician:	Initials:
Nature of the maintenance:		

Inspection date:	Technician:	Initials:
Nature of the maintenance:		

Inspection date:	Technician:	Initials:
Nature of the maintenance:		

# 14 EC Declaration of conformity

**SPIROTECH**  Maximising Performance for You

## EC Declaration of Conformity

Manufacturer: **Spirotech BV**  
Address: **Churchillaan 52**  
**5705 BK Helmond**  
**The Netherlands**

Spirotech BV declares that the **SpiroVent Superior S250** complies with following European Directives:

Low voltage Directive	(2014/35/EC)
Electromagnetic compatibility Directive	(2014/30/EC)
Pressure equipment Directive	(2014/68/EC)
ROHS Directive	(2011/65/EC)
(Restriction of the use of certain hazardous substances in electric and electronic equipment)	
Waste from electric and electronic equipment Directive	(2012/19/EC)

The following harmonised standards have been applied:

EN 60335-1 (2012)	Household and similar electrical appliances -Safety- Part 1: General requirements.
EN 61000-6-2 (2019)	Electromagnetic compatibility (EMC) - Part 6-2: Generic standards – Immunity standard for industrial environments.
EN 61000-6-3 (2007)	Electromagnetic compatibility (EMC) - Part 6-3: Generic standards – Emission standard for equipment in residential environments.
EN 61000-3-2 (2019)	Electromagnetic compatibility (EMC); limits for harmonic current emissions.
EN 61000-3-3 (2013)	Electromagnetic compatibility (EMC); limitation of voltage changes, voltage fluctuation and flicker.

Helmond, April 2021

.....  
  
J. Jacobs  
(COO Spirotech BV)

15

**UK Declaration of conformity**

**SPIROTECH**  Maximising Performance for You

## UK Declaration of Conformity

Manufacturer: **Spirotech BV**  
 Address: **Churchillaan 52**  
**5705 BK Helmond**  
**The Netherlands**

Spirotech BV declares that the **SpiroVent Superior S250** complies with following UK Legislation:

Electrical Equipment (Safety) Regulations 2016  
 Electromagnetic Compatibility Regulations 2016  
 Pressure Equipment (Safety) Regulations 2016  
 The Restriction of the Use of Certain Hazardous Substances in Electrical and Electronic Equipment Regulations 2012  
 The Waste Electrical and Electronic Equipment Regulations 2013

The following harmonised standards have been applied:

BS EN 60335-1 (2012)	Household and similar electrical appliances -Safety- Part 1: General requirements.
BS EN 61000-6-2 (2019)	Electromagnetic compatibility (EMC) - Part 6-2: Generic standards – Immunity standard for industrial environments.
BS EN 61000-6-3 (2007)	Electromagnetic compatibility (EMC) - Part 6-3: Generic standards – Emission standard for equipment in residential environments.
BS EN 61000-3-2 (2019)	Electromagnetic compatibility (EMC); limits for harmonic current emissions.
BS EN 61000-3-3 (2013)	Electromagnetic compatibility (EMC); limitation of voltage changes, voltage fluctuation and flicker.

Helmond, April 2021

  
 .....  
 J. Jacobs  
 (COO Spirotech BV)



The manufacturer reserves the right to make changes without prior notification.

© Copyright Spirotech bv  
Information given in this brochure may not be reproduced complete or in part without the prior written consent of Spirotech bv.